

Shuttle 2+2 2005

ELECTRONIC SPEED CONTROL

Read all of Section B and this section before attempting any procedure. Pay particular attention to all Notes, Cautions and Warnings

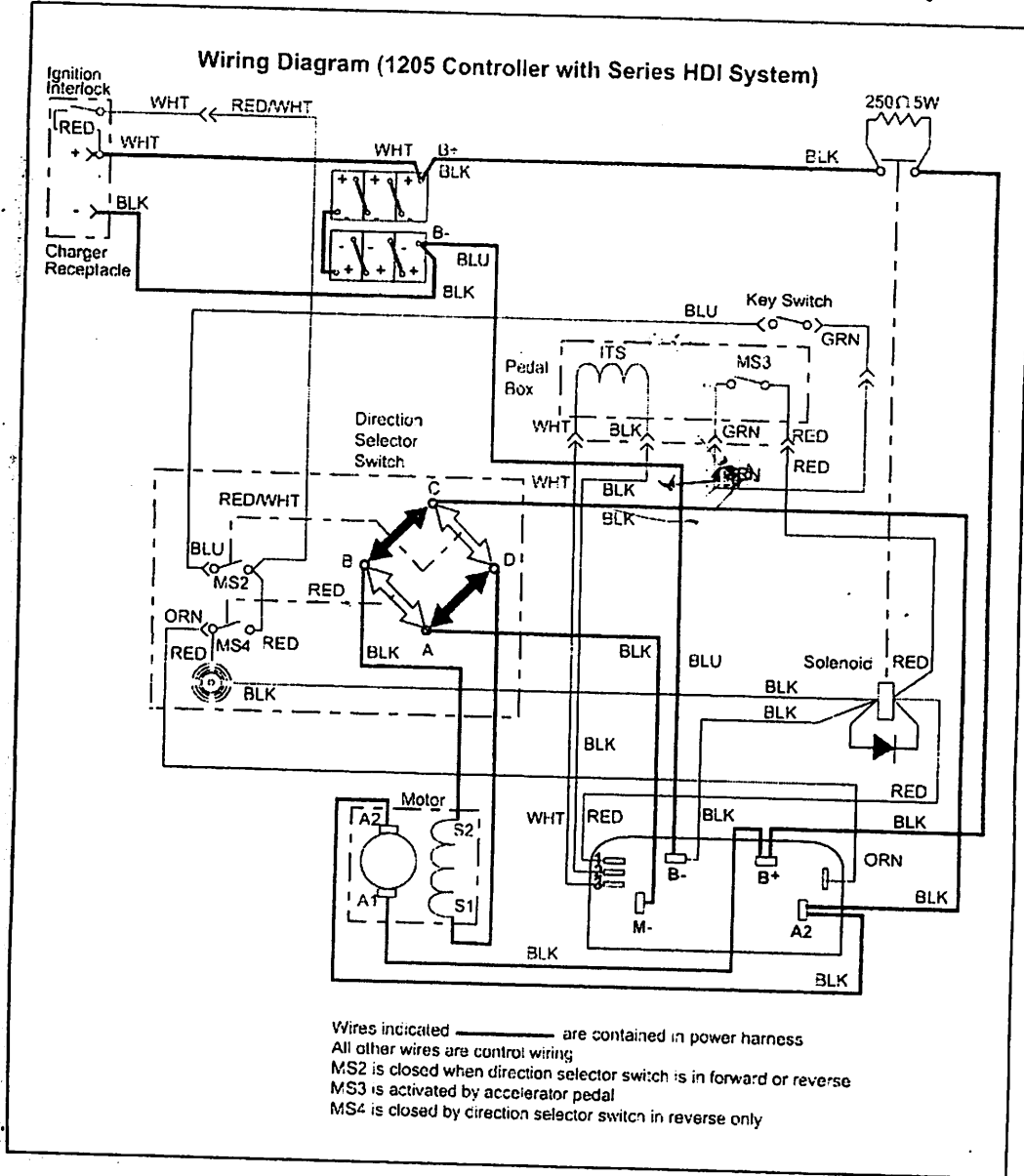

Fig. 18 Wiring Diagram

6534Z